

ITEM NO.	PART NUMBER	QTY.
1	Plate	1
2	Motor mount	1
3	Inch - LH Helical gear 12DP 32T 10HA 14.5PA 0.5FW ---32N3.0H2.0L0.5N	1
4	worm	1
5	End plate	1
6	o Plate	1
7	fr8zz	2
8	fr6zz	1
9	CIM Motor	1
10	500 hex to 8mm adapter	1
11	worm shaft	1
12	worm spacer	2
13	8mm spacer	1
14	output shaft	1
15	SPS 0.1875x0.75	2
16	Preferred Narrow FW 0.25	1
17	SBHCSCREW 0.25-20x0.625-HX-C	1
18	HX-SHCS 0.19-32x1.75x0.875-C	4
19	encoder bracket	1
20	HX-SHCS 0.19-32x0.375x0.375-C	2
21	10-32_nylock_nut	4
22	worm gear ring	2

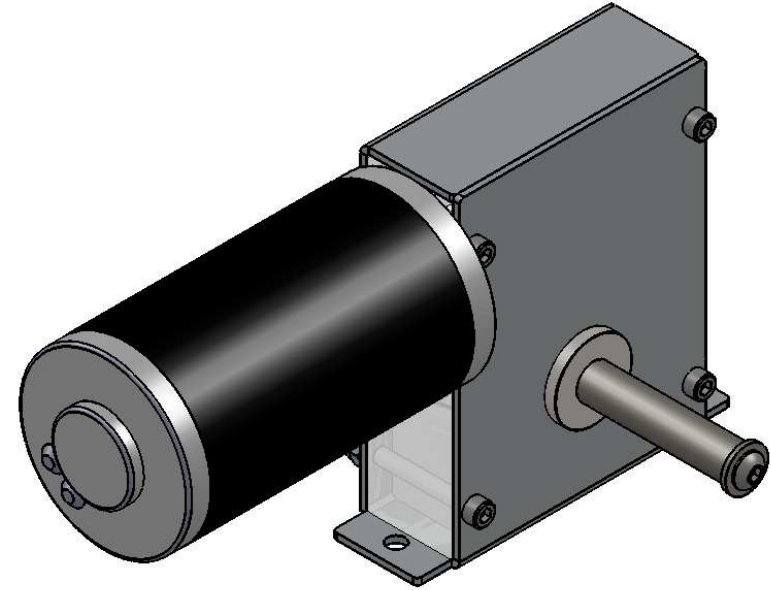

<p><b>PROPRIETARY AND CONFIDENTIAL</b></p> <p>THE INFORMATION CONTAINED IN THIS DRAWING IS THE SOLE PROPERTY OF &lt;INSERT COMPANY NAME HERE&gt;. ANY REPRODUCTION IN PART OR AS A WHOLE WITHOUT THE WRITTEN PERMISSION OF &lt;INSERT COMPANY NAME HERE&gt; IS PROHIBITED.</p>			UNLESS OTHERWISE SPECIFIED:		NAME	DATE			
			DIMENSIONS ARE IN INCHES TOLERANCES: FRACTIONAL ± ANGULAR: MACH ± BEND ± TWO PLACE DECIMAL ± THREE PLACE DECIMAL ±	DRAWN			TITLE:		
			INTERPRET GEOMETRIC TOLERANCING PER:	CHECKED					
			MATERIAL	ENG APPR.					
	NEXT ASSY	USED ON	FINISH	MFG APPR.			Q.A.		
APPLICATION		DO NOT SCALE DRAWING	COMMENTS:				SIZE	DWG. NO.	REV
							<b>A</b>	<b>WormBox</b>	
							SCALE: 1:4	WEIGHT:	SHEET 1 OF 2

5

4

3

2

1

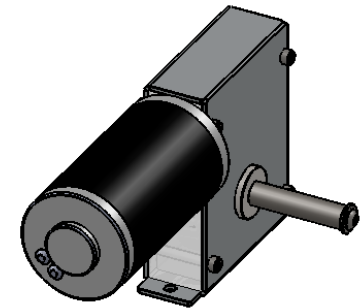
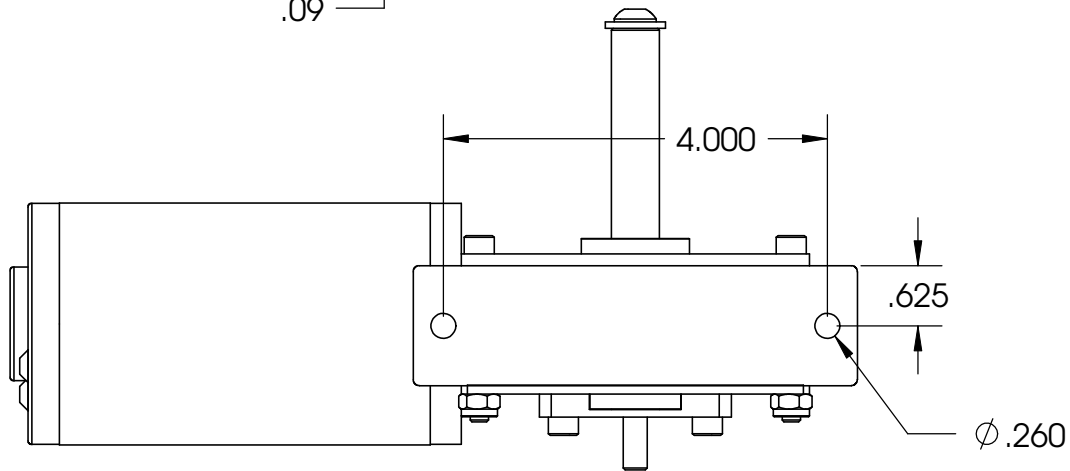
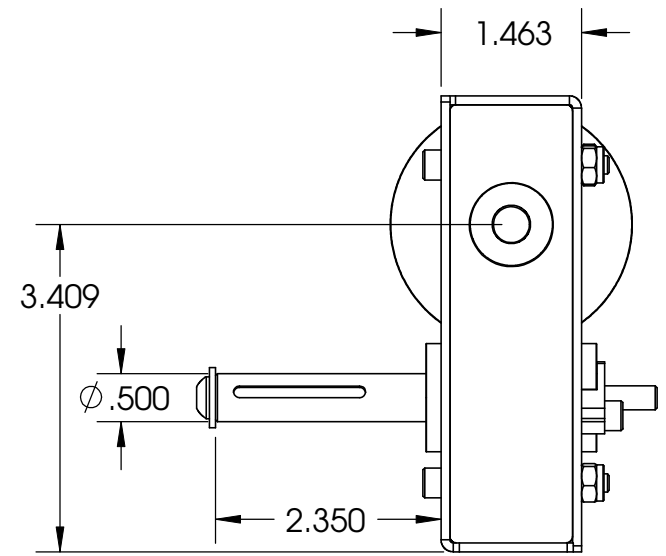
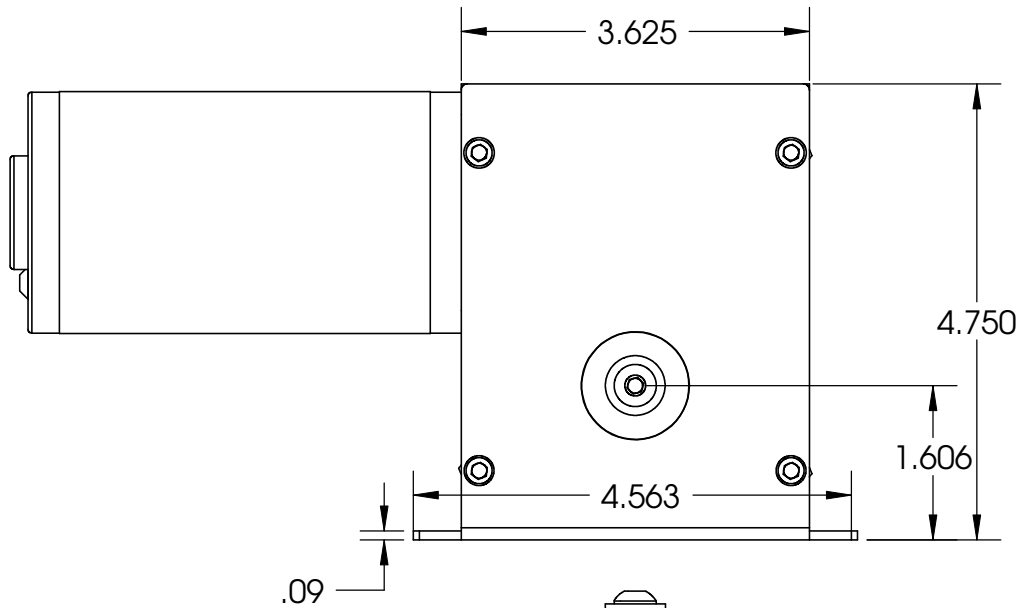

**PROPRIETARY AND CONFIDENTIAL**  
 THE INFORMATION CONTAINED IN THIS DRAWING IS THE SOLE PROPERTY OF <INSERT COMPANY NAME HERE>. ANY REPRODUCTION IN PART OR AS A WHOLE WITHOUT THE WRITTEN PERMISSION OF <INSERT COMPANY NAME HERE> IS PROHIBITED.

		UNLESS OTHERWISE SPECIFIED:		NAME	DATE
		DIMENSIONS ARE IN INCHES	DRAWN		
		TOLERANCES:	CHECKED		
		FRACTIONAL ±	ENG APPR.		
		ANGULAR: MACH ± BEND ±	MFG APPR.		
		TWO PLACE DECIMAL ±	Q.A.		
		THREE PLACE DECIMAL ±	COMMENTS:		
		INTERPRET GEOMETRIC TOLERANCING PER:			
		MATERIAL			
		FINISH			
NEXT ASSY	USED ON				
APPLICATION		DO NOT SCALE DRAWING			

TITLE:		
SIZE	DWG. NO.	REV
<b>A</b>	<b>WormBox</b>	
SCALE: 1:4	WEIGHT:	SHEET 2 OF 2