



Gear Ratio Table and Output Speed Calculations

Input stage includes a 15T 32DP pinion (am-3482) that meshes with an 85T gear (am-3533) for the first stage. User choose two gear pairs for their A (default) and B Ratio. An optional 3rd stage provides an additional C ratio choice of 1:1.14 or 2:1.

Ratios can be compared using the Output Speed calculated using the following equation:

$$\frac{CIM\ Speed(rev)}{1\ (min)} * \frac{1\ (min)}{60\ (sec)} * \frac{\pi}{Diameter(in)} * \frac{1\ (ft)}{12\ (in)} * \frac{1}{Gear\ Ratio} = Output\ Speed\ (ft/s)$$

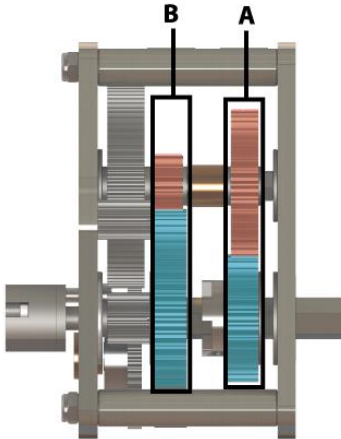

2 Stage Options												
Final Ratio	Code	Ratios A and B				Ratio C				Calculated Output Speed* (ft/s)		
		3/8 Hex Cluster Gear		4 Tooth Dog Gear		1/2" Hex Output Cluster Gear	1/2" Hex Final Output Gear			4" Wheel	6" Wheel	8" Wheel
04.77:1	047	38T	am-3538	32T	am-3489	None				15.00	22.49	29.99
06.00:1	060	34T	am-3537	36T	am-3539					11.93	17.89	23.84
07.56:1	075	30T	am-3536	40T	am-3490					9.47	14.21	18.93
10.86:1	108	24T	am-3485	46T	am-3540					6.59	9.88	13.17
16.37:1	163	18T	am-3534	52T	am-3541					4.37	6.56	8.74
22.67:1	226	14T	am-3484	56T	am-3491					3.16	4.74	6.31

*Based on calculations using two CIM motors running at 4100rpm, or 75% of free speed to account for efficiency losses.

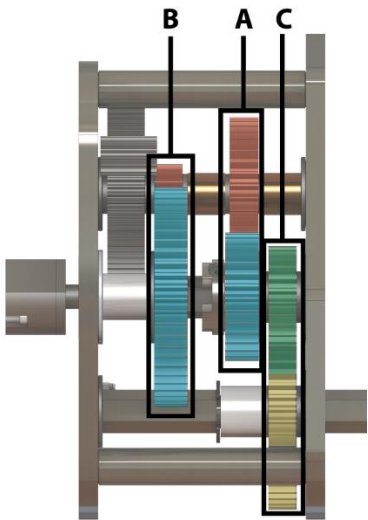

3 Stage Options												
Final Ratio	Code	Ratios A and B				Ratio C				Calculated Output Speed** (ft/s)		
		3/8 Hex Cluster Gear		4 Tooth Dog Gear		1/2" Hex Output Cluster Gear	1/2" Hex Final Output Gear			4" Wheel	6" Wheel	8" Wheel
05.45 :1	054	38T	am-3538	32T	am-3489	35T	am-3486	40T	am-3487	11.04	16.57	22.09
06.86 :1	068	34T	am-3537	36T	am-3539	35T	am-3486	40T	am-3487	8.78	13.18	17.57
08.63 :1	086	30T	am-3536	40T	am-3490	35T	am-3486	40T	am-3487	6.98	10.46	13.95
09.54 :1	095	38T	am-3538	32T	am-3489	25T	am-3535	50T	am-3488	6.31	9.47	12.62
12.00 :1	120	34T	am-3537	36T	am-3539	25T	am-3535	50T	am-3488	5.02	7.53	10.04
12.41 :1	124	24T	am-3485	46T	am-3540	35T	am-3486	40T	am-3487	4.85	7.28	9.70
15.11 :1	151	30T	am-3536	40T	am-3490	25T	am-3535	50T	am-3488	3.99	5.98	7.97
18.71 :1	187	18T	am-3534	52T	am-3541	35T	am-3486	40T	am-3487	3.22	4.83	6.44
21.72 :1	217	24T	am-3485	46T	am-3540	25T	am-3535	50T	am-3488	2.77	4.16	5.55
25.90 :1	259	14T	am-3484	56T	am-3491	35T	am-3486	40T	am-3487	2.33	3.49	4.65
32.74 :1	327	18T	am-3534	52T	am-3541	25T	am-3535	50T	am-3488	1.84	2.76	3.68
45.33 :1	453	14T	am-3484	56T	am-3491	25T	am-3535	50T	am-3488	1.33	1.99	2.66

**Based on calculations using two CIM motors running at 3451rpm, or 65% of free speed to account for efficiency losses.